

General information

PWS35420240703

Among the weight transmitters, DAT 11 is the fastest to receive, convert and transmit data thanks to a more performing A/D converter. Thanks to its small size and compact design, the DAT 11 weight transmitter can be inserted in any work environment without taking up too much space. DAT 11 is a customizable product that has a mechanical keyboard with a programmable key block from which it is possible to manually set the weight filter with predetermined values or with individually adjustable parameters. The DAT 11 weight transmitter features removable screw terminal blocks, selectable logic input function, voltage or current analog input, unipolar or bipolar analog output, RS485 junction box connection and peak hold function for dynamic measurements. DAT 11 is a product in step with the times. It complies with EN45501, and the Fieldbus data are updated to 125Hz. Compared to traditional weight transmitters, DAT 11 contains a USB port which allows the firmware update, the connection to the Optimization software and the connection to TESTER 1008, which facilitates calibration and troubleshooting. DAT 11 is able to perform various calibrations: "Dead Weight", "Theoretical" and "Data Sheet". In addition, it presents the linearization of the weight calibration on 5 points. Developed specifically by Pavone Weighing Systems and installed free of charge in the weighing instrument, the Optimization software allows you to simplify and perform various operations such as configuring the instrument and correctly and safely saving data through the DATALOGGER function.

Software Optimization 1.8.29: [optimization_weighing_software.zip](#)Technical Manual: [dat-11_technical_manual.pdf](#)

All indicated data may be changed without notice.
All the measures indicated are expressed in millimeters (mm).

Technical specifications

PWS35420240703

Measuring range:	-7.6 ÷ +7.6 mV/V
Input sensitivity:	0.02 µV/count
Full scale non-Linearity:	<0.01%
Gain drift:	0,001% FS/°C
Display:	6 digit, 7-segment LED red, height 8mm
A/D Converter:	24 bit
Internal Resolution:	> di 16.000.000 points
Visible resolution (in divisions):	999999
Divisions value (adjustable):	x1, x2, x5, x10, x20, x50
Decimal figures range:	0 ÷ 4
Temperature range:	-10 ÷ +50°C (max umidity 85% without condensation)
Storage temperature:	-20 ÷ +60°C
Filter:	0.1 ÷ 250 Hz
Excitation voltage:	4 Vdc (max 4 -350 Ohm- load cells)
Logic output:	2 optoisolated outputs; max 24 Vdc/100 mA each
Logic input:	2 optoisolated inputs 24 Vdc PNP (external power supply)
Serial port:	1 USB-C device + 1 RS232C and 1 RS485 with ASCII or Modbus RTU protocol or 1 Fieldbus
Analog output Non-Linearity:	<0.03%
Temperature drift analog output:	0,002% FS/°C
Power supply:	24 Vdc ±10% - power consumption 5 W
Microcontroller:	ARM Cortex M0 + 32 bit 256KB Flash reprogrammable onboard via USB
Data storage:	32 Kbytes expandable up to 1024 Kbytes (optional)
Regulatory compliance:	EN61000-6-2, EN61000-6-3, EN61326-1 for EMC, EN61010-1 for Electrical Safety

All indicated data may be changed without notice.
 All the measures indicated are expressed in millimeters (mm).

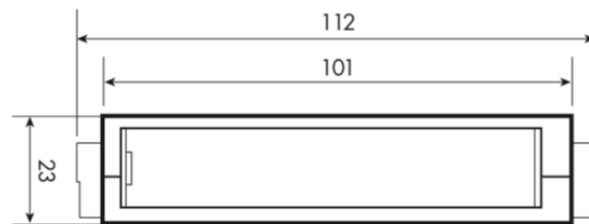
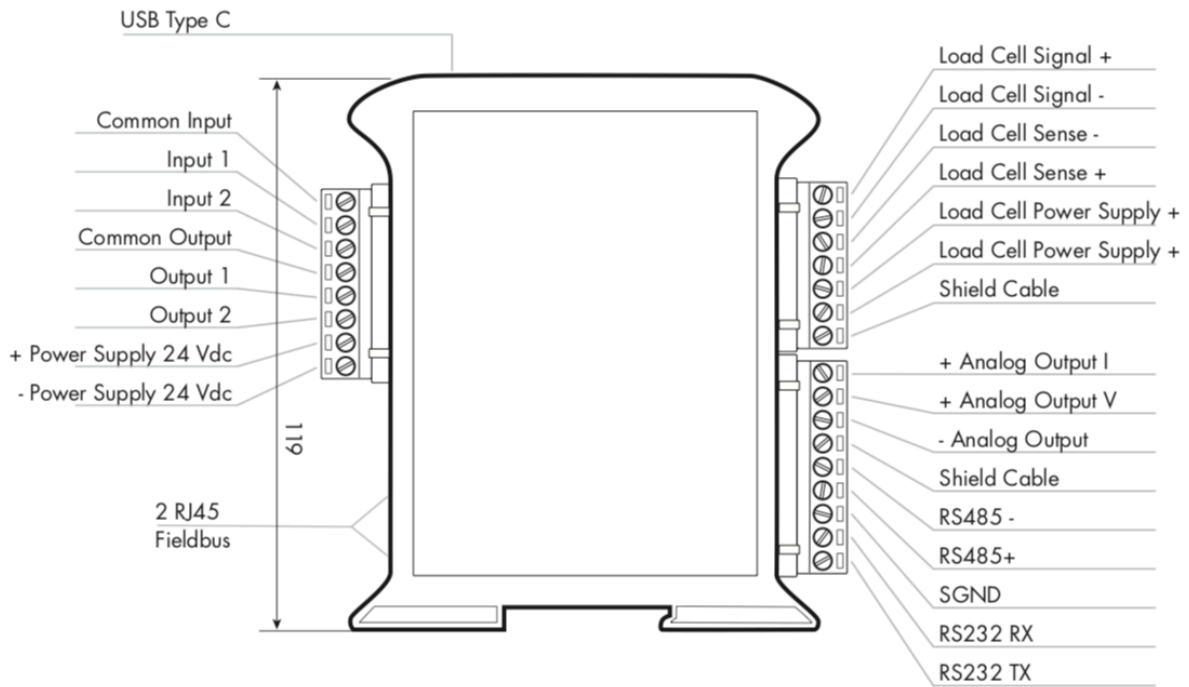

All indicated data may be changed without notice.
All the measures indicated are expressed in millimeters (mm).