

Technical specifications

PWS32420250222

MCT 1302 Analog + Ethernet IP is a touch screen weight indicator ideal for all types of weighing, in particular for static weighing and loading / unloading and multicomponent dosing. It is easy to install and use and can be customized as needed. MCT 1302 Analog + Ethernet IP has multilingual menu, extractable screw terminal blocks, internal data memory of 64 Kbytes expandable up to 1024 Kbytes and simultaneous availability of fieldbus and analogue output. The Software Optimization is given for free. This Software allows you to run certain activities such as calibration or monitoring directly from your computer. The Optimization software is provided by Pavone Systems and guarantees a perfect instrument run.

Legal for Trade:	certification available on request
Measuring range:	-3.9 ÷ +3.9 mV/V
Input sensitivity:	0.02 µV/count
Full scale non-Linearity:	<0.01%
Gain drift:	< 0.001% FS/°C
Display:	graphic LCD (240x128 pixel)
A/D Converter:	24 bit; internal resolution up to 16.000.000
Transducer input voltage:	5 Vdc (max 8 load cells - 350 Ohm)
Frequency signal acquisition:	12 ÷ 1000 Hz
Visible resolution (in divisions):	999999
Divisions value (adjustable):	x1, x2, x5, x10, x20, x50; max 4 decimals
Temperature range:	-10 ÷ + 50°C (humidity max 85% no condensation)
Storage temperature:	-20 ÷ +70°C
Filter:	0.1 ÷ 250 Hz
Logic output:	6 opto-isolated; max 24 Vdc/100mA each
Logic inputs:	6 optically isolated 24 Vdc PNP (external power supply)
Additional I/O:	up to 4 external modules with 4 in/8-out each (16 in/32 out, total) by independent RS485
Serial port:	1 USB device + 1 RS232C + 1 RS485/Fieldbus
Power supply:	18÷30 Vdc - Power consumption 5 W
Microcontroller:	ARM Cortex M0 + 32 bit 256KB Flash reprogrammable onboard from USB
Data storage:	64 Kbytes expandable up to 1024 Kbytes
Regulatory compliance:	EN61000-6-2, EN61000-6-3 for EMC; EN61010-1 for Electrical Safety, EN45501 for metrology
Drilling template:	138 x 82 mm (L x H)
Dimensions:	150x95x26mm (LxWxH) including terminal blocks; 150x95x56mm (WxHxD) with fieldbus options



All indicated data may be changed without notice.
All the measures indicated are expressed in millimeters (mm).

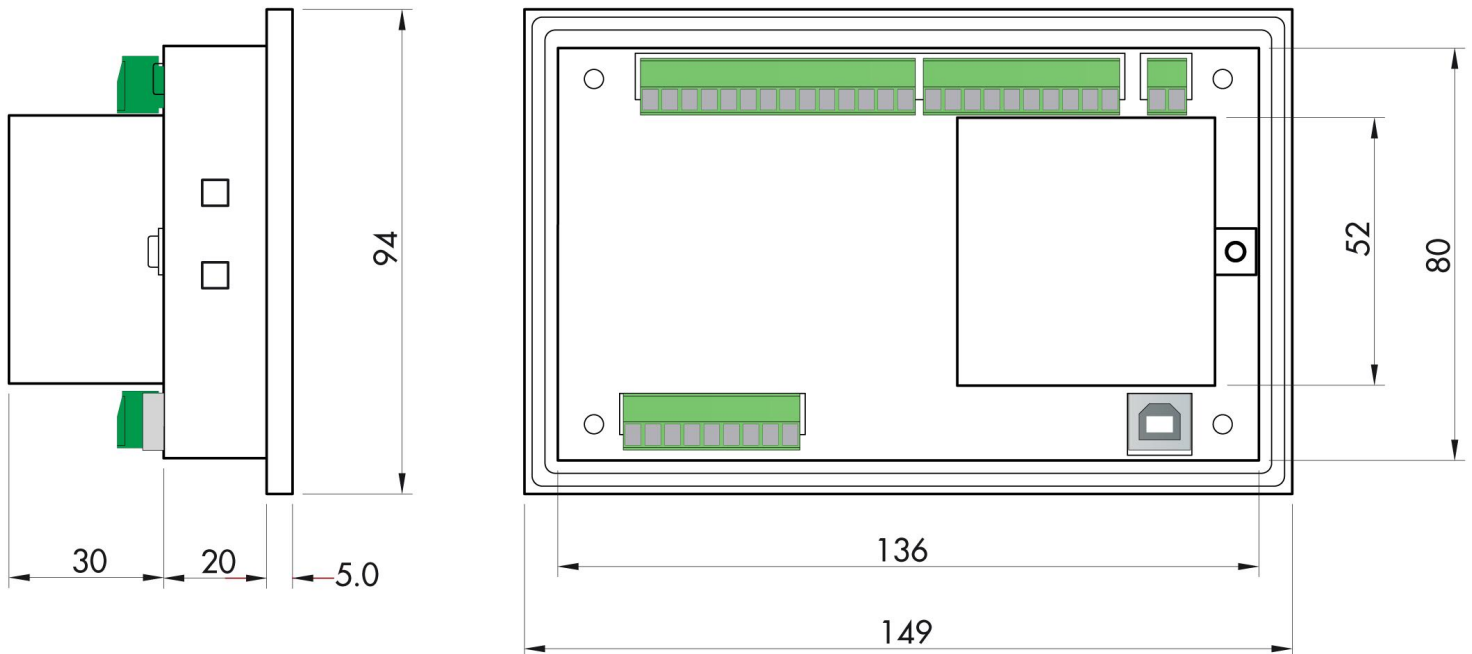

All indicated data may be changed without notice.
 All the measures indicated are expressed in millimeters (mm).

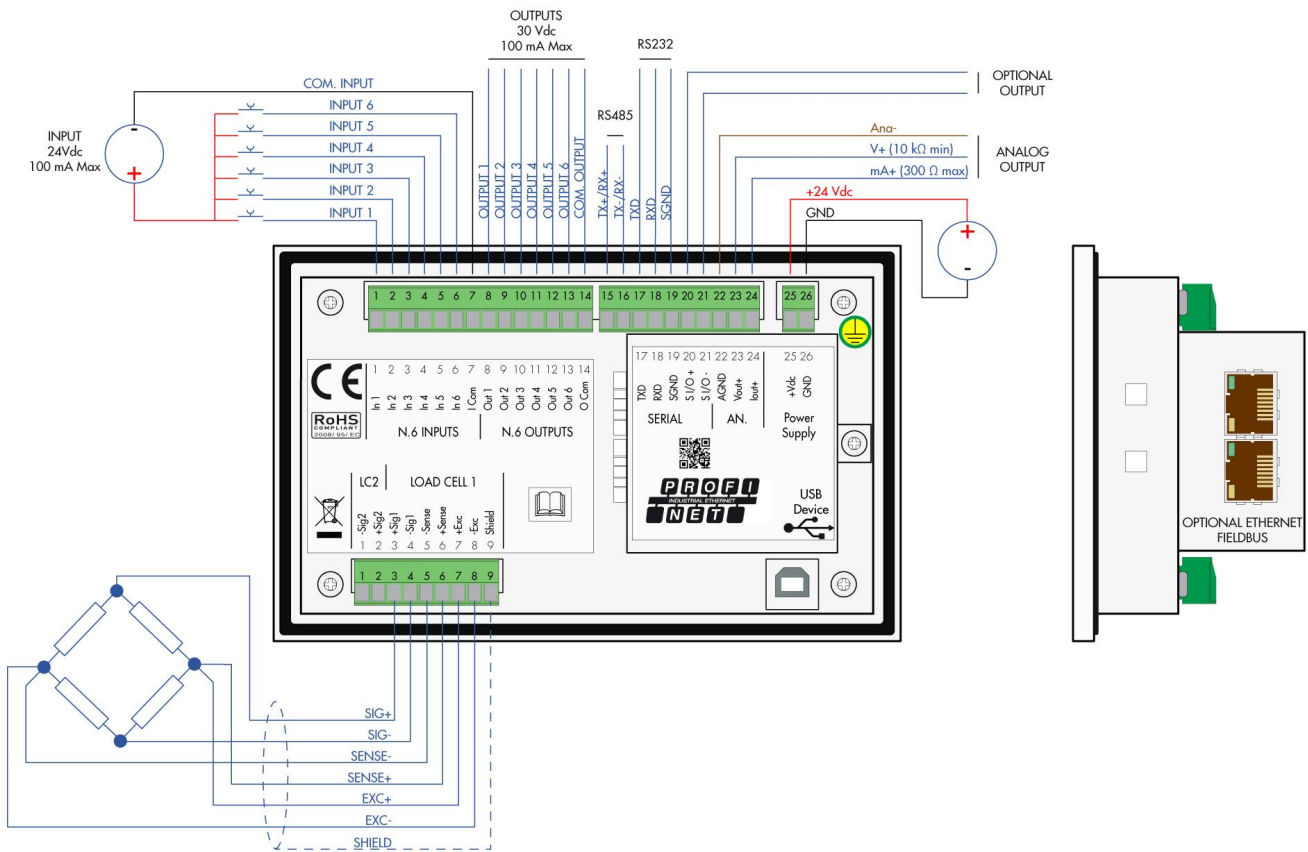

All indicated data may be changed without notice.
 All the measures indicated are expressed in millimeters (mm).