

General information

PWS29320240703

MCT 1302 Batch meets various needs in the weighing field: from simple management of level thresholds to complicated dosing procedures. The MCT 1302 Batch weighing solution is able to totalize the dosed weights divided by recipe and to store up to 100 different recipes with 20 steps. With an expandable memory, it can save up to 1000 recipes with 20 steps. The MCT 1302 Batch has a touch screen, an upload and download function for programming via TESTER 1008 and useful software for programming and saving recipes directly on the PC and transmitted via USB. MCT 1302 Batch has 6 logic inputs and 6 logic outputs and 4 optional Fieldbus: Profinet, Ethernet IP, Ethercat and Profibus. The MCT 1302 Batch dosing instrument can be customized according to customer needs.



Technical Manual: [mct-1302-batch_technical_manual.pdf](#)

Software Optimization 1.8.29: [optimization_weighing_software.zip](#)

Software Recipe 1.1.15: [pwin_recipe_weighing_software.zip](#)

All indicated data may be changed without notice.
All the measures indicated are expressed in millimeters (mm).

Technical specifications

PWS29320240703

Legal for Trade:	certification available on request
Measuring range:	-3.9 ÷ +3.9 mV/V
Input sensitivity:	0.02 µV/count
Full scale non-Linearity:	<0.01 % full scale
Gain drift:	< 0.001% FS/°C
Display:	graphic LCD (240x128 pixel)
A/D Converter:	24 bit; internal resolution up to 16.000.000
Transducer input voltage:	5 Vdc (max 8 cells -350 Ohm)
Frequency signal acquisition:	12 ÷ 1000 Hz
Visible resolution (in divisions):	999999
Divisions value (adjustable):	x1, x2, x5, x10, x20, x50; max 4 decimals
Temperature range:	-10 ÷ +50°C (humidity max 85% no condensation)
Storage temperature:	-20 ÷ +70°C
Filter:	0.1 ÷ 250 Hz
Logic output:	6 opto-isolated; max 24 Vdc/100mA each
Logic input:	6 optically isolated 24 Vdc PNP (external power supply)
Additional I/O:	up to 4 external modules with 4 in/8-out each (16 in/32 out, total) by independent RS485
Serial port:	1 USB device + 1 RS232C + 1 RS485/Fieldbus
Power supply:	18 ÷ 30 Vdc - Power consumption 5 W
Microcontroller:	ARM Cortex M0 + 32 bit 256KB Flash reprogrammable onboard from USB
Data storage:	64 Kbytes expandable up to 1024 Kbytes
Regulatory compliance:	EN61000-6-2, EN61000-6-3 for EMC; EN61010-1 for Electrical Safety, EN45501 for metrology
Drilling template:	138 x 82 mm (L x H)
Dimensions:	150x95x26mm (LxWxH) including terminal blocks; 150x95x56mm (WxHxD) with fieldbus options; drilling template: 138x82mm
Fieldbus:	Ethernet 10/100 con protocolli TCP, MODUBUS/TCP, UDP, IP, ICMP, ARP; Profinet; Ethernet/IP; Ethercat

All indicated data may be changed without notice.
All the measures indicated are expressed in millimeters (mm).



All indicated data may be changed without notice.
All the measures indicated are expressed in millimeters (mm).

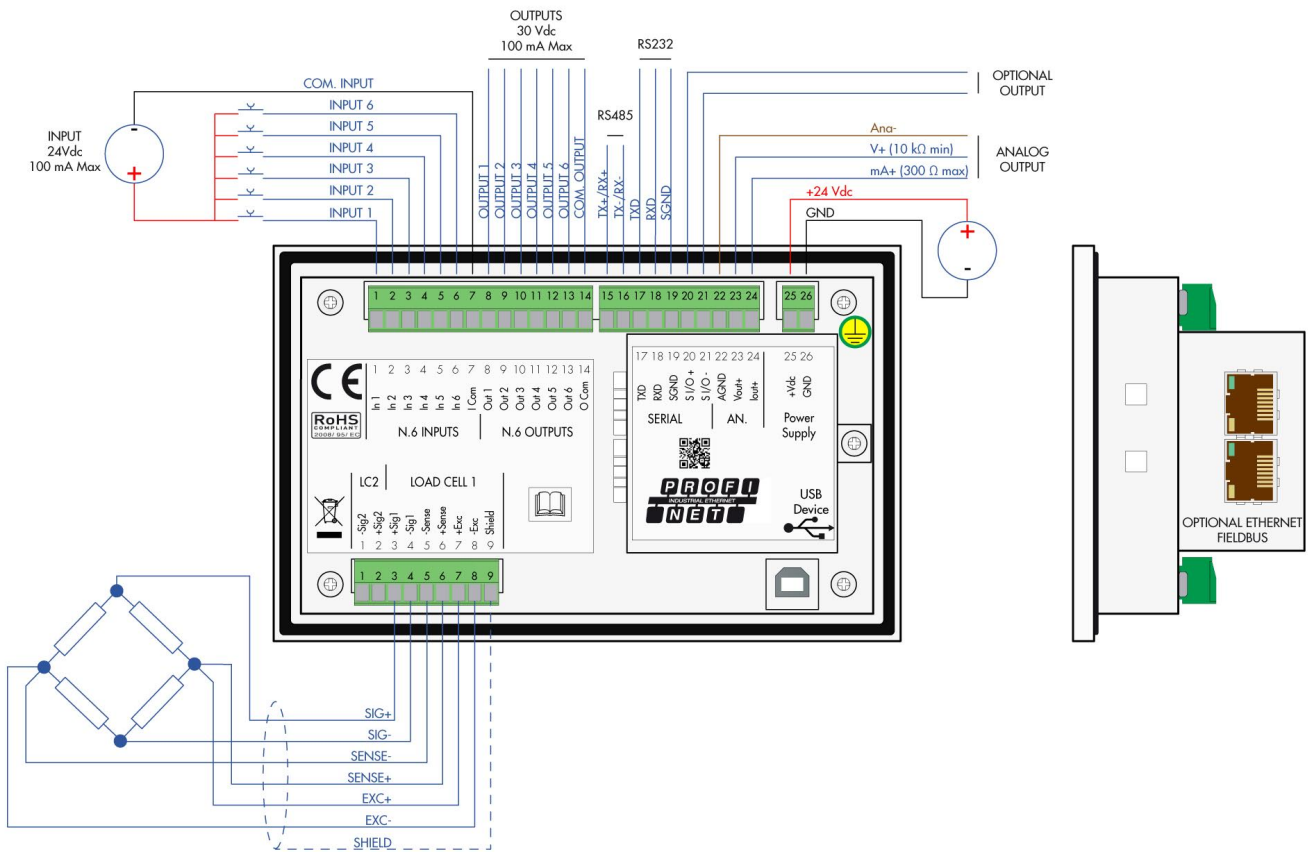

All indicated data may be changed without notice.
 All the measures indicated are expressed in millimeters (mm).