

General information

PWS35320250222

The ATEX MC 315 weight indicator, designed and manufactured by Pavone Weighing Systems in accordance with Directive 2014/34/EU and in compliance with EN 60079-0:2018, EN 60079-11:2012, EN 60079-26:2015, is a weighing instrument with ATEX certification that can be used in environments with potentially explosive atmospheres, particularly in zones ATEX 1, 21 and in zones ATEX 2, 22 (1 and 2 for gases, 21 and 22 for dust). The low energy used by the weight indicator is not sufficient to trigger explosions neither with electrical sparks nor with excessive temperatures (class T4), thus making the use of the ATEX MC 315 weight indicator safe in areas with risk of explosion. The fiber optic connection of the ATEX MC 315 weight indicator allows the necessary information to be brought to the safe area without Zener barriers to obtain the voltage or current analogue output via the S318 interface. As an alternative to the RS232 and RS485 ports, Pavone Weighing Systems provides the following Fieldbuses: Profibus, Profinet, Ethernet IP, Ethercat.

The version with rechargeable battery box (charger for recharging in a safe area) is available on request.



All indicated data may be changed without notice.
All the measures indicated are expressed in millimeters (mm).

Technical specifications

PWS35320250222

Measuring range:	-3,9 ÷ +3,9 mV/V
Input sensitivity:	0.02 µV/count
Full scale non-Linearity:	<0.01% of full scale
Gain drift:	<0.002% of full scale/°C
A/D Converter:	24 bit
Visible resolution (in divisions):	up to 999.999 divisions on payload
Decimal figures range:	0 ÷ 4
Temperature range:	-10 ÷ +40 °C
Storage temperature:	-20 ÷ +50 °C
Filter:	0.25 ÷ 50 Hz
Logic output:	6 photorelay, max 24 Vcc/100mA each
Logic inputs:	2 optoisolated 12 ÷ 24 Vcc PNP (external power supply)
Serial port:	2 x RS485 with ASCII or Modbus RTU protocols; maximum cable lenght = 200 meters
Fiber optic ports:	1 x FULL DUPLEX with data transmission to S318 card in safe area; Duplex type cable with Plastic Optical Fiber of 1 mm (ex: COP-1002-HD) and maximum length of 50 meters
Power supply:	100 ÷ 250 Vac from AL-AX certified power supply or from 6V battery via AL-BX barrier (in safe area)
Regulatory compliance:	for EMC = EN61000-6-2, EN61000-6-3; for Electrical Safety = EN61010-1; for ATEX = EN60079-0, EN60079-11, EN60079-26
Fieldbus:	Profibus, Profinet, Ethernet IP, Ethercat
Transducer input voltage:	3.3 V (max 4 load cells 350 Ohm)

All indicated data may be changed without notice.
All the measures indicated are expressed in millimeters (mm).

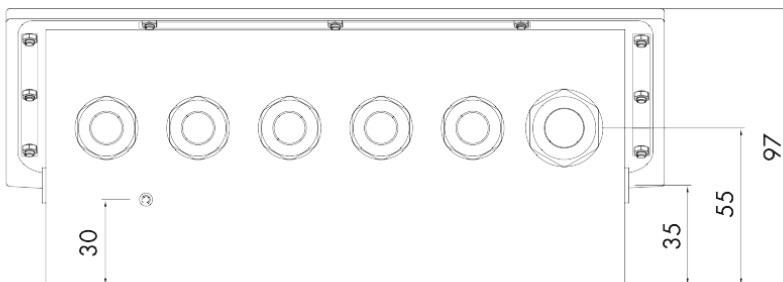
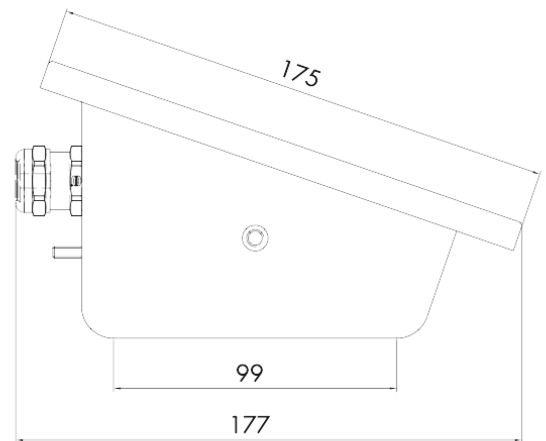
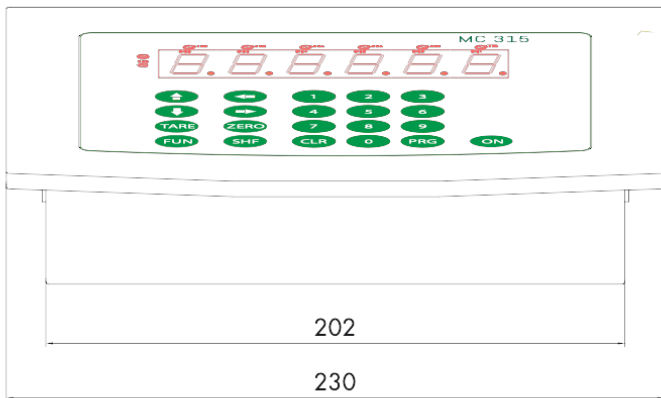

All indicated data may be changed without notice.
All the measures indicated are expressed in millimeters (mm).