

Technical specifications

PWS16620241012

The MCWHU dynamometer is a solution designed for mobile weighing with a high capacity for industrial weighing, ideal for warehouses and more hostile environments. It is used above all in the steel, mechanical and food industry, where it is necessary to weigh significant suspended loads. The MCWHU product is equipped with a weight indicator and equipped with a wi-fi connection to communicate in real time with remote devices. The MCWHU dynamometer has a waterproof keypad with 5 keys (zero, automatic tare, mode, print and on / off), a plexiglass protective screen, a radiofrequency remote control and other options on request (hook and bell, heat shield for protection against infrared rays and high temperatures, accessories connected in radiofrequency etcetera).

Display:	red LED 40 mm
Degree of protection:	IP67
Temperature range:	-10 ÷ 80°C
Power supply:	230 Vac 50 Hz
Weight:	86 kg
Accuracy:	±0.1 % full scale



All indicated data may be changed without notice.
All the measures indicated are expressed in millimeters (mm).

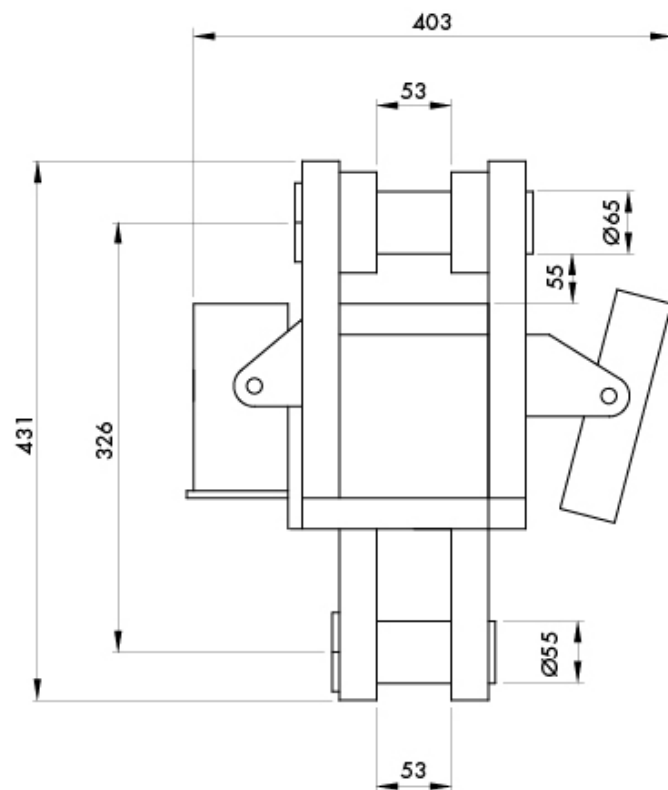
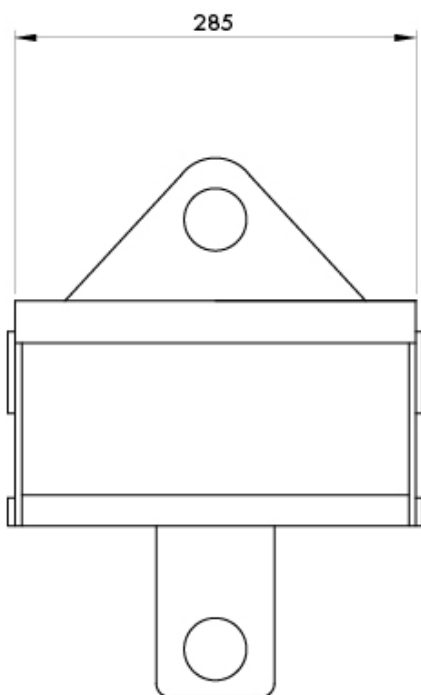

All indicated data may be changed without notice.
All the measures indicated are expressed in millimeters (mm).

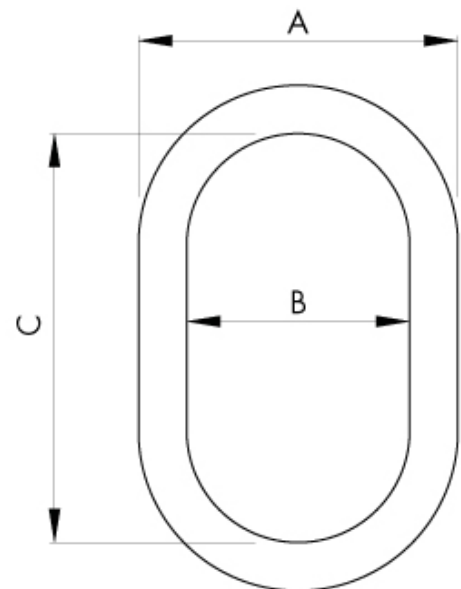
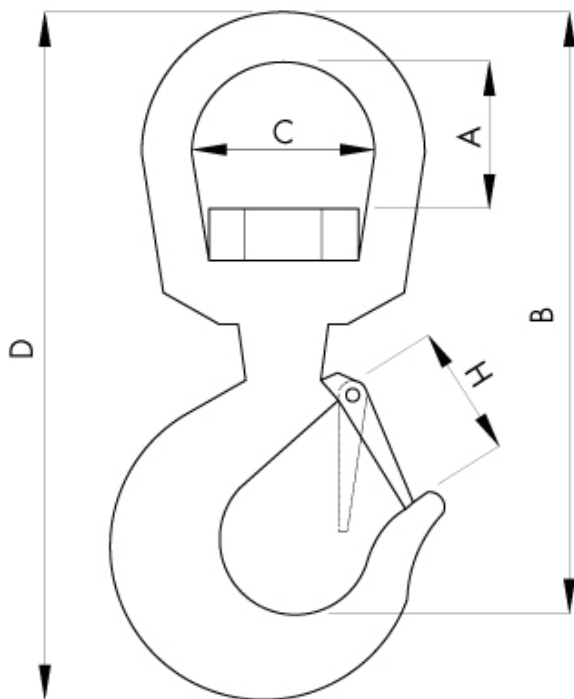

All indicated data may be changed without notice.
All the measures indicated are expressed in millimeters (mm).